

**Model:** ENERGY  
**ET38V**

**SPECIFICATIONS:**

Year of Intro	2000
Thrust	38 LBS
Volts	12VDC
Amp Draw	0 to 48 amps
Mount	03 Transom
Speeds	Variable

**TO ORDER PARTS:**

MotorGuide Consumer Relations  
Phone 918-831-6989  
Fax 800-982-8093

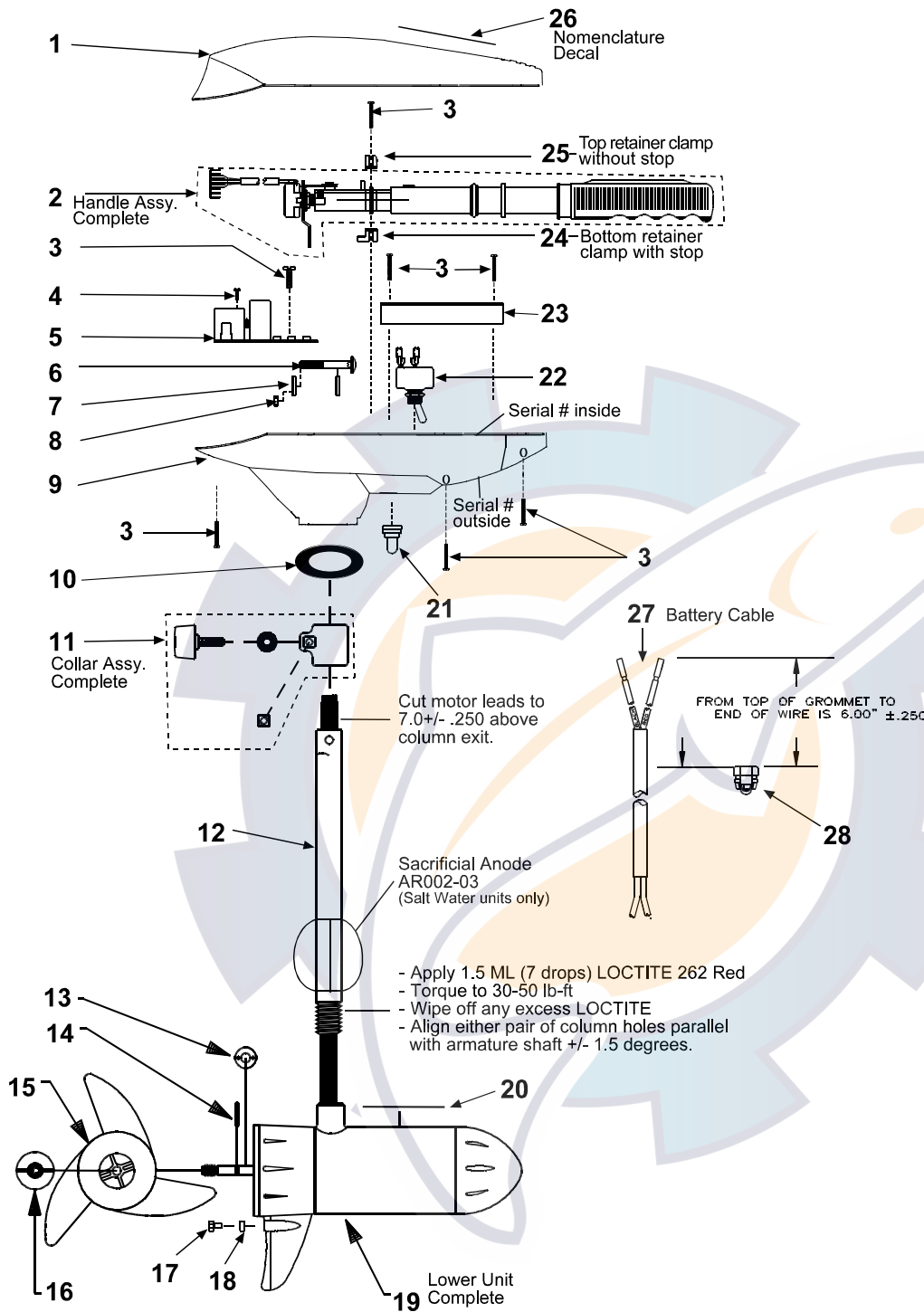

KEY	DESCRIPTION	PART #	KEY	DESCRIPTION	PART #	KEY	DESCRIPTION	PART #
1	TOP HOUSING COVER BLACK	ET053-17	12	COLUMN 36"	TT049-05	20	LOWER UNIT COMPLETE	ET060-08
2	HANDLE ASY	ET372-06	13	COLUMN 42"	TT049-06	21	SWITCH BOOT	FP177-01
3	#8 X 5/8 SCREW	AT141-01	14	COLUMN 50"	FR049-13	22	TOGGLE SWITCH	FP153-07
4	#4 SELF TAPPING SCREW	XT141-02	15	PROP/3 BLADE	AR175-01	23	CABLE PLATE	AT155-06
5	CIRCUIT BOARD FOR/REV	AT157-01	16	PROP DRIVE PIN	BR102-01	24	BOTTOM RETAINER CLAMP	AR036-02
6	BOLT	TT134-02	17	PROP/2 BLADE	AF124-12	25	UPPER RETAINER CLAMP	AR036-04
7	CURVED WASHER	TT171-08	18	PROP NUT	AF124-07	26	NOMENCLATURE DECAL	NT056-13
8	NYLON LOCK NUT	XT098-02	19	MOTOR	AR099-01	27	BATTERY CABLE	XT328-06
9	T/H BASE BLACK	AT004-11			DK133-01	28	GROMMET	GR019-01
10	COLUMN SEAL	AT079-01			AR002-02			
11	DEPTH ADJUSTMENT COLLAR	AR158-01			KF397-08			

# LOWER UNIT BREAKDOWN

Model: **ENERGY**  
**ET38V**

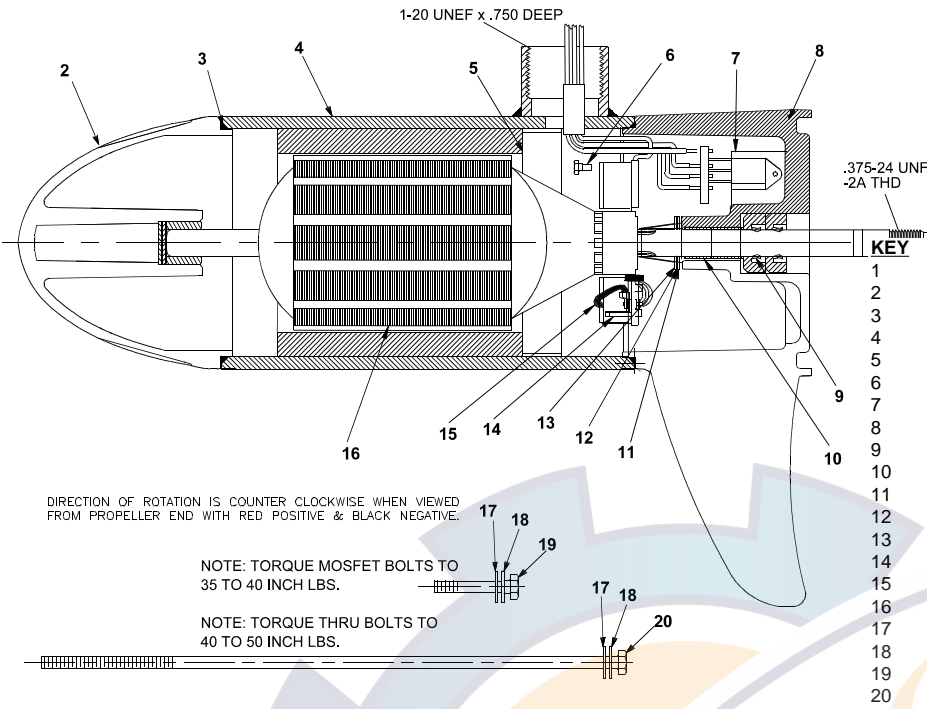

DIRECTION OF ROTATION IS COUNTER CLOCKWISE WHEN VIEWED FROM PROPELLER END WITH RED POSITIVE & BLACK NEGATIVE.

NOTE: TORQUE MOSFET BOLTS TO 35 TO 40 INCH LBS.

NOTE: TORQUE THRU BOLTS TO 40 TO 50 INCH LBS.

## WIRING

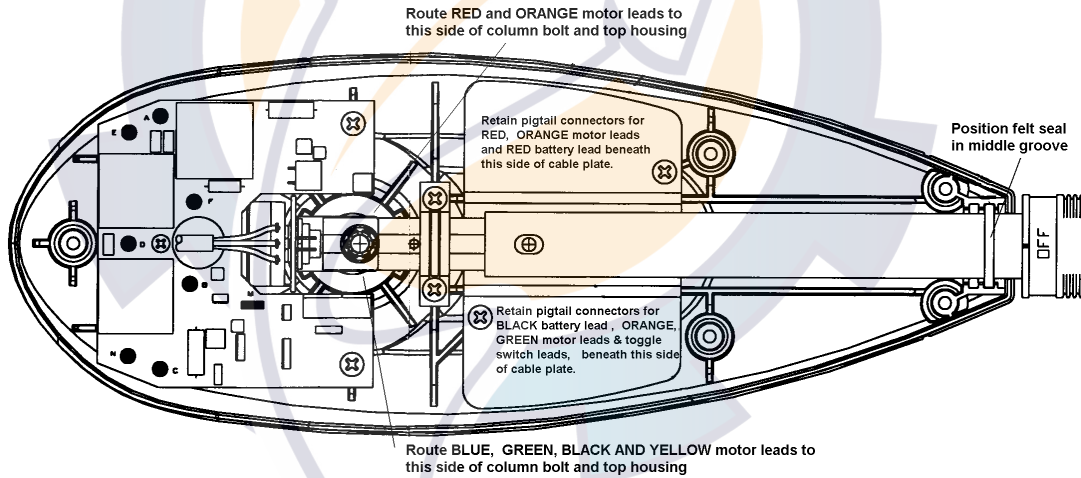

TOP HOUSING

MOTOR HOUSING

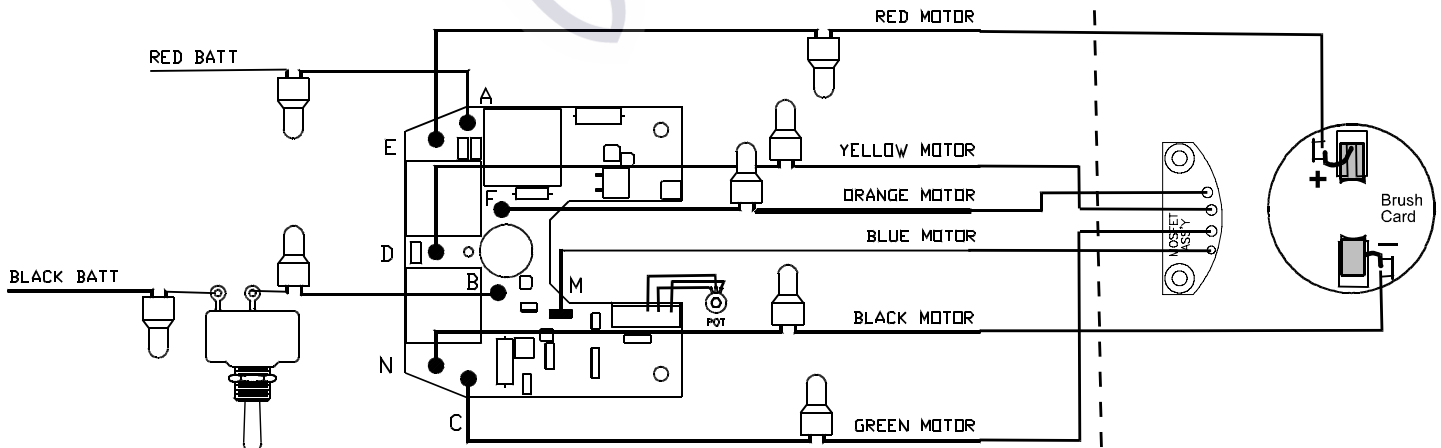

SUBJECT TO DAMAGE BY STATIC ELECTRICITY  
ASSEMBLE AT STATIC FREE WORK STATION!